

Installation instruction

Micro BLC



The Mymesh micro BLC is a product in the Chess program for building light control. The micro BLC is a wireless light controller for DALI and 0..10V drivers. The micro BLC is powered by the DALI controller or by an auxiliary power supply. The micro BLC can optionally be extended with one of the following PIR motion sensors:

5606.6402.001	Add-on slight motion PIR	Range: 3m, Hor. 360°, Ver. 104°	
5606.6401.001	Add-on Standard sensitivity PIR	Range: 7m, Hor. 360°, Ver. 100°	
5606.6400.001	Add-on high bay PIR	Range: 12m, Hor. 360°, Ver. 69°	
5606.6403.001	Add-on wide angle PIR	Range: 5m, Hor. 150°, Ver. 35°	

Safety



- Installation and service should be performed by qualified personnel only.
- The electrical installation must be in conformance with the national legislation and relevant standards.
- Do not use the micro BLC if it is damaged.
- The micro BLC is suitable for use at indoor locations (IP20 protection class). Mount the micro BLC in an IP66 housing for use at outdoor locations.

Application

Refer to the micro BLC product sheet (see chess.nl) for the environmental conditions.

Installation

Mount the micro BLC on a flat surface using the delivered two-sided tape.

- Use 0.2-0.5 mm² (AWG24-20) solid wiring for the 3-port push-in wire connector. Ensure to remove 7 ± 0.5 mm of the isolation. Push the wires completely into the connector. Use wire end sleeves (AWG24-20) when using flexible wires.
- Warning: wires cannot be removed anymore.
- De micro BLC can be wired in two configurations: DALI or 0..10V driver. See wiring diagrams below.
- Optionally a PIR motion sensor can be connected. Drill a 16mm hole to mount the PIR. Push the PIR from the outside into the hole. The PIR will fixate itself in the hole with the rubber ribbons. See diagram below.
- Connect the PIR with the delivered cable to the 4-port connector on the micro BLC.
- One micro BLC controls one luminaire. It is only allowed to connect a DALI Emergency driver as a second driver on the DALI BUS

PIR mounting:

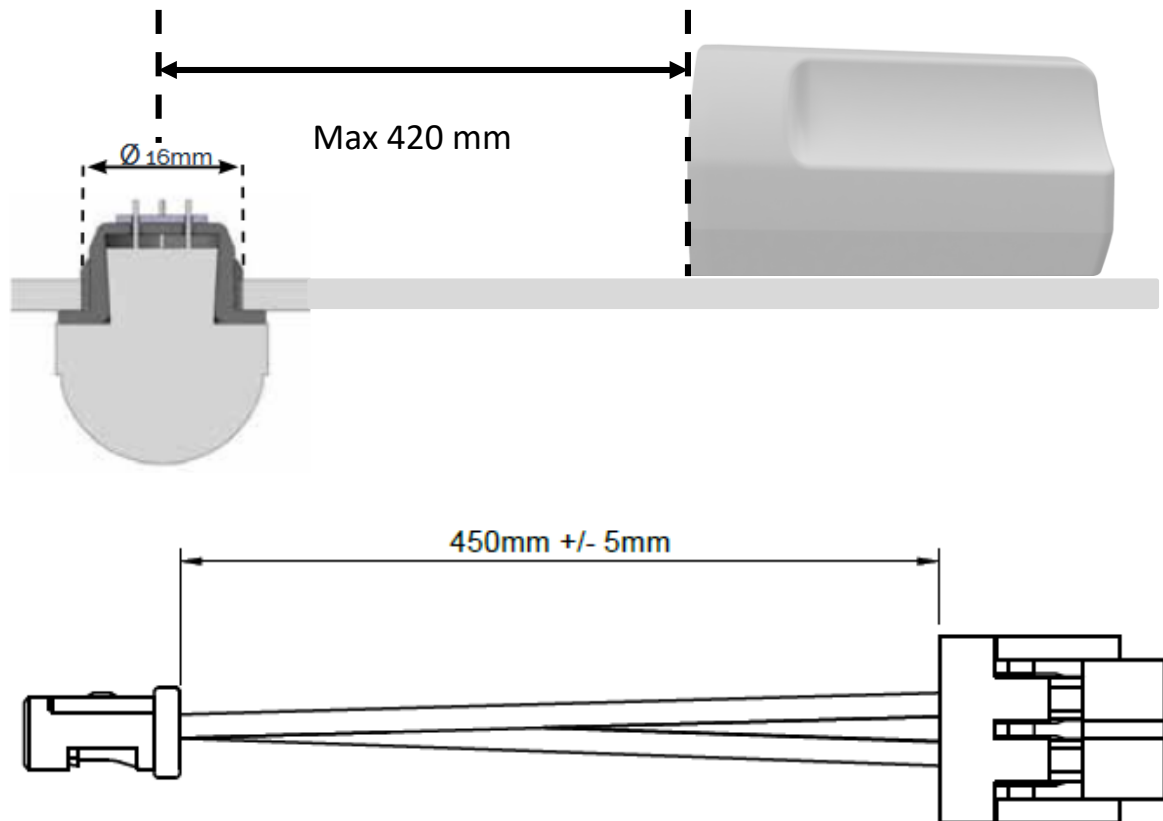

Antenna mounting

The micro BLC contains at the top side an (internal) antenna for wireless communication with other Mymesh products. Operation of the antenna should not be disrupted.

- Do **not** mount the micro BLC inside a metal housing or directly next to a large metal object.
- Some glass and plastic materials such as safety glass, tinted glass and double glass influence the operation of an antenna.
- Use a plastic, polycarbonate or fiberglass housing **without** carbon
- Mount the micro BLC **outside** the fixture if necessary.
- Depending on the installation of the Micro BLC in the luminaire the range is damped to a greater or lesser extent. The range of the antenna is divided into four categories:
 - ★★★★★ – 75 to 100% antenna range for situations where luminaires are installed far apart in an open space (approx. 30-50 meters) **OR** for situations where luminaires are installed in close proximity (approx. 20-30 meters) in complex buildings with a lot of damping through walls, partitions and ceilings
 - ★★★☆☆ – 50 to 75% antenna range is acceptable for situations where luminaires are installed in close proximity (approximately 10-20 meters) in buildings with limited attenuation due to partitions.
 - ★☆☆☆☆ – 25 to 50% antenna range is acceptable for situations where luminaires are installed in an open space in close proximity (approximately 10-20 meters).
 - ☆☆☆☆☆ – no antenna range. Do not apply.
- The following installation examples of the antenna are for illustrative purposes. Contact Chess in case of doubt.



Figure 1: Do not place the Micro BLC in a metal housing / fixture.

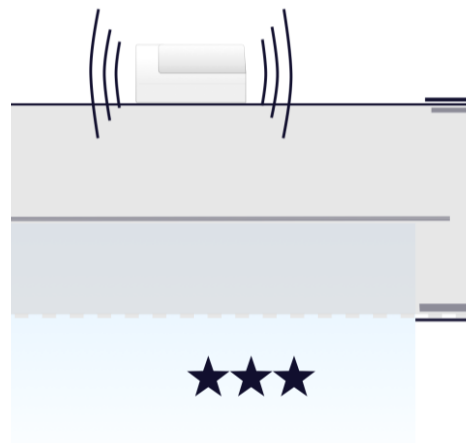

Figure 2: Place the Micro BLC outside a metal housing / fixture.

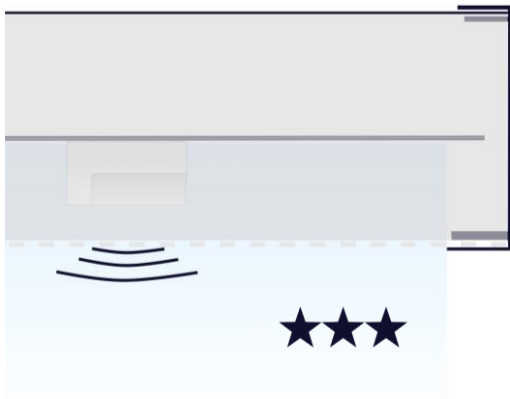

Figure 3 : In case of a metal fixture place the Micro BLC on the side of the light diffuser.

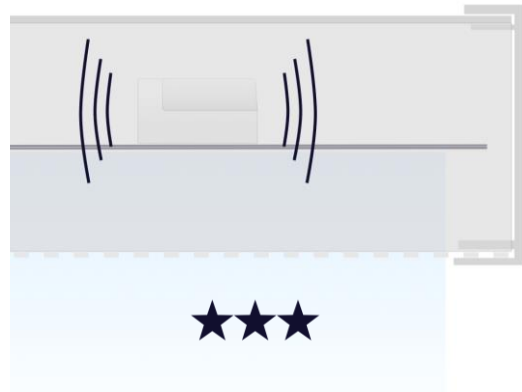

Figure 4 : Place the Micro BLC in a full plastic housing / fixture.

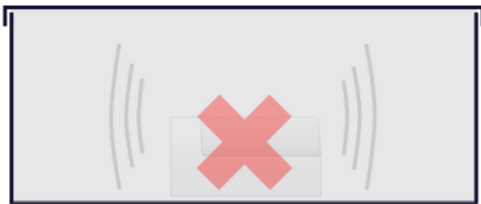

Figure 5 : Do not place the Micro BLC in a metal housing / junction box.



Figure 6 : Place the Micro BLC in a full plastic housing / junction box.



Wiring diagrams

The Micro BLC is powered by a DALI power supply or an auxiliary power supply. The DALI power supply can be supplied by the DALI driver or a separate DALI power supply component.

The Micro BLC provides an open collector output for operation with 0-10V LED drivers. The Led driver (or an external circuit) should provide +10V in this case as shown below.

Contact Chess in case of doubt.

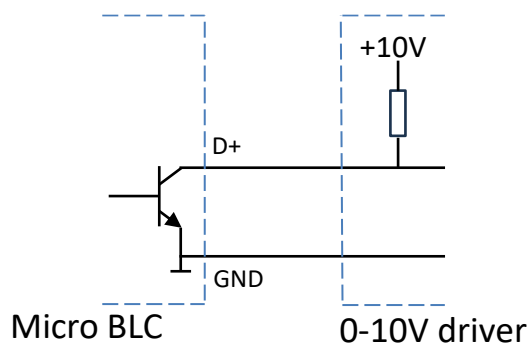

Option 1: DALI driver with integrated DALI Power Supply

The Micro BLC can be easily connected to a DALI driver with integrated DALI Power Supply such as Philips SR, Osram Dexal, Tridonic IDPS or D4i LED Drivers.

The power for the Micro BLC is supplied by the DALI driver.

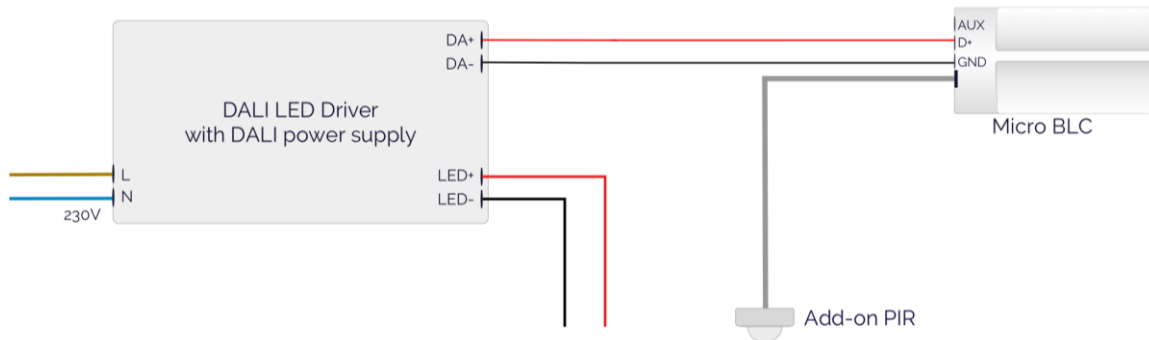

Option 2: 0..10V dimmable driver with auxiliary power supply

To connect a Micro BLC to a 0-10V dimmable LED driver, the Micro BLC must be powered by an always-on 12V or 24V auxiliary power supply.

The power for the Micro BLC is provided by the auxiliary power supply.

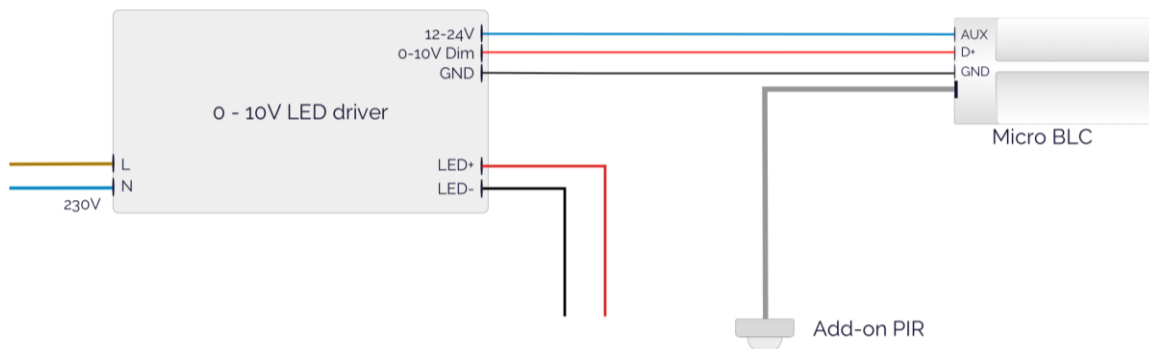

Warning: auxiliary power supplies should be connected to the AUX input (never to the D+ input)

Option 3: DALI driver without integrated DALI Power Supply

To connect a Micro BLC to a standard DALI driver, the DALI BUS must be powered by a DALI Power Supply component.

The power for the Micro BLC is supplied by the DALI Power Supply component.

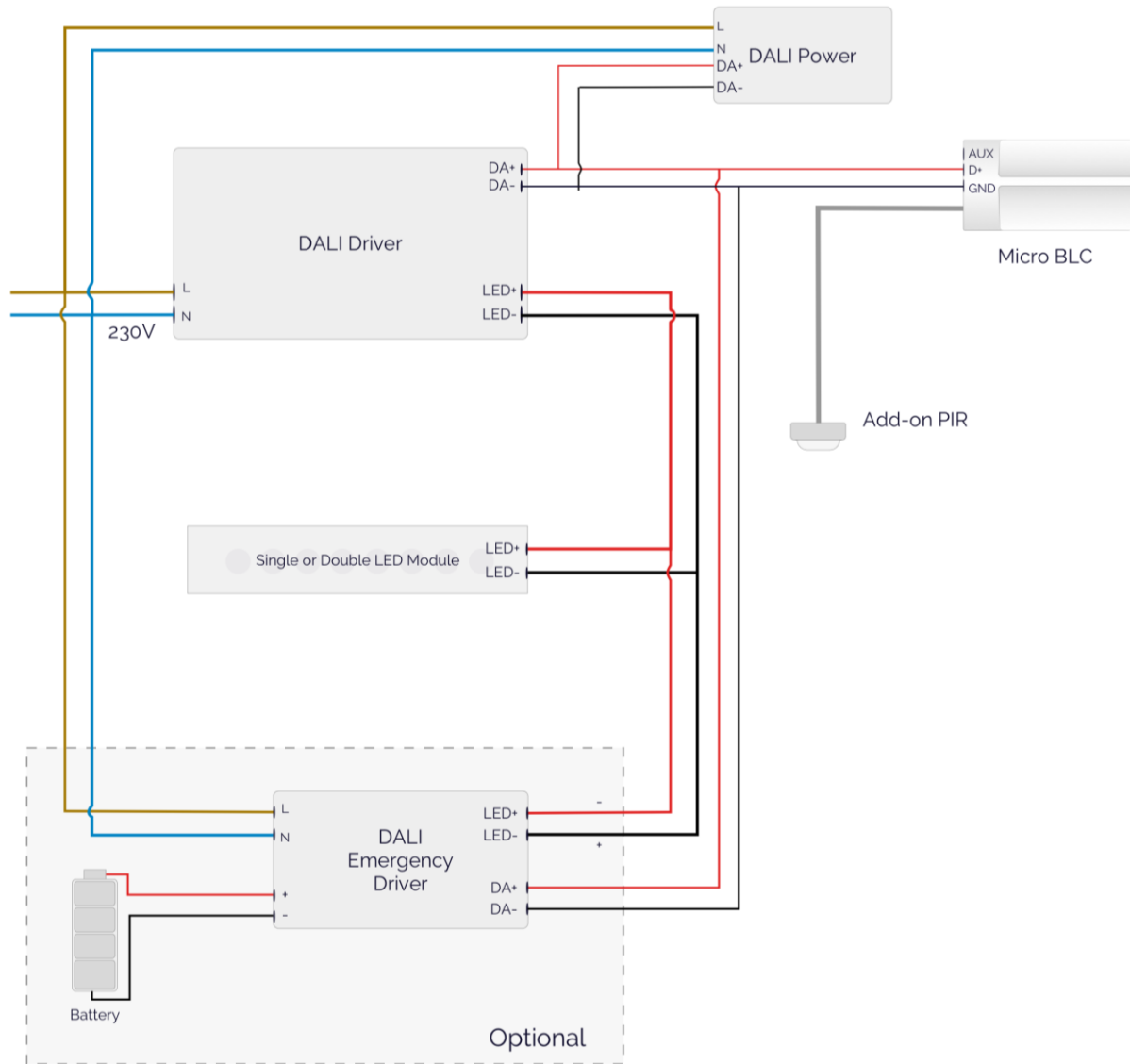

Configuration

When the micro BLC is powered, the connected lamp should go on. Use the iPad Mymesh commission app for configuration of the micro BLC.

The micro BLC is shown in the commission app with a lamp symbol. The micro BLC is not able to detect the presence of a connected PIR sensor. This needs to be configured in the sensor tab of the micro BLC. When the sensor is enabled, a combined lamp/sensor symbol is shown.



Usage

The micro BLC will control the connected driver and lamp.

Compliance



This product complies with the European directives and relevant standards for RED, REACH and RoHS. The micro BLC contains a 2.4 Ghz radio. The applied frequency of the radio is within the band 2.401 – 2.482 GHz and the maximum transmit power is +4 dBm.

Hereby, Chess Wise B.V. declares that the radio equipment type micro BLC is in compliance with Directive 2014/53/EU. The full text of the EU declaration of conformity will be available at chess.nl.

Repair

Do not open this product. In case of failure the micro BLC must be replaced.



Recycling

Do not dispose this product as household waste, but bring it to an appropriate collection point for recycling.