

Installation instruction

BLC200

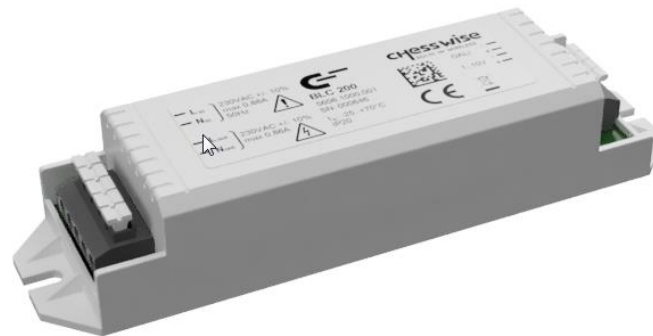

The Mymesh BLC200 is a product in the Chess program for building light control. The BLC200 is a wireless light controller for DALI and 1..10V drivers. A relay is available to control the power to the driver and lighting fixture.

Safety



- Installation and service should be performed by qualified personnel only.
- The electrical installation must be in conformance with the national legislation and relevant standards.
- The mains connection of the BLC200 must be provided with a fuse or circuit breaker.
- Disconnect power at the source before installation, inspection or removal.
- Do not use the BLC200 if it is damaged.
- The BLC200 is suitable for use at indoor locations (IP20 protection class). Mount the BLC200 in an IP66 housing for use at outdoor locations.

Application

Refer to the BLC200 product sheet (see chess.nl) for the maximum ratings of the relay and the environmental conditions. Add an external 230VAC relay with overvoltage protection if needed (e.g. Schneider AgC20732 + AgC15920).

Installation

- Install the BLC200 in the direct neighborhood of other Mymesh products.
- Mount the BLC200 with 2x M4 screw/bolt (140mm distance) or double sided tape.
- Use maximal 1.5 mm² (AWG16) wiring for all connections. Push the wires completely into the terminal block. Use wire end sleeves when using flexible wires.
- De BLC200 can be wired in three configurations: DALI driver, 1..10V driver or a 230V load. See wiring diagrams below.
- Use either 1..10V or DALI, not both.
- One BLC200 controls one luminaire.
- The BLC200 contains at the secondary side an (internal) antenna for wireless communication with other Mymesh products. Operation of the antenna should not be disrupted.
 - Do not mount the BLC200 inside a metal housing or directly next to a large metal object.
 - Some glass and plastic materials influence the operation of an antenna.
 - Mount the BLC200 outside the luminaire if necessary.
 - Contact Chess in case of doubt.

BLC200 + DALI driver:

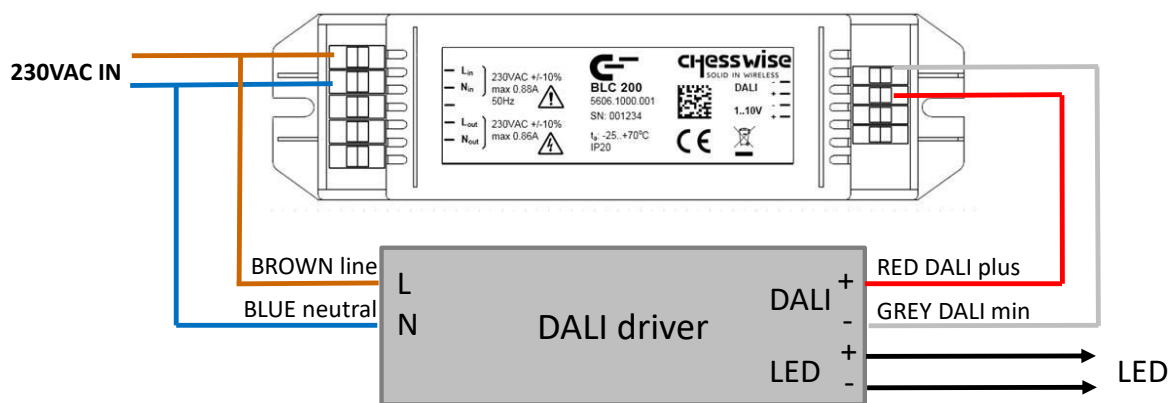

Connect the power input of a DALI driver directly to the 230V mains.

BLC200 + 1..10V driver:

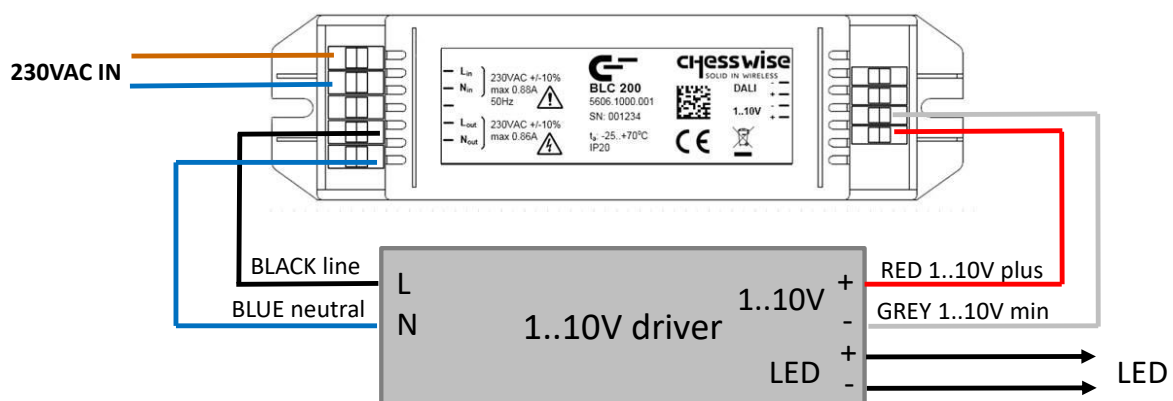

Connect the power input of a 1..10V driver to the switched 230V output of the BLC200.

BLC200 + 230V load:

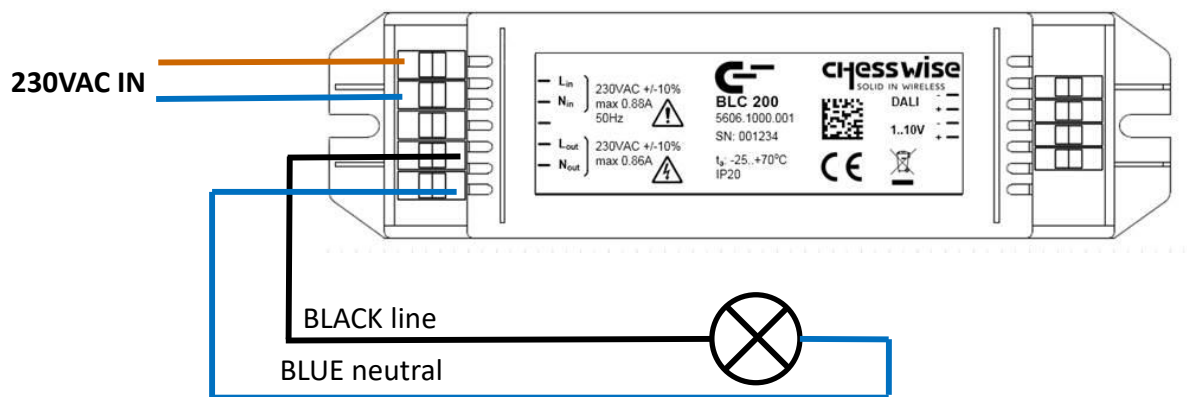

Connect the 230V load to the switched 230V output of the BLC200

BLC200 + 230V relay:

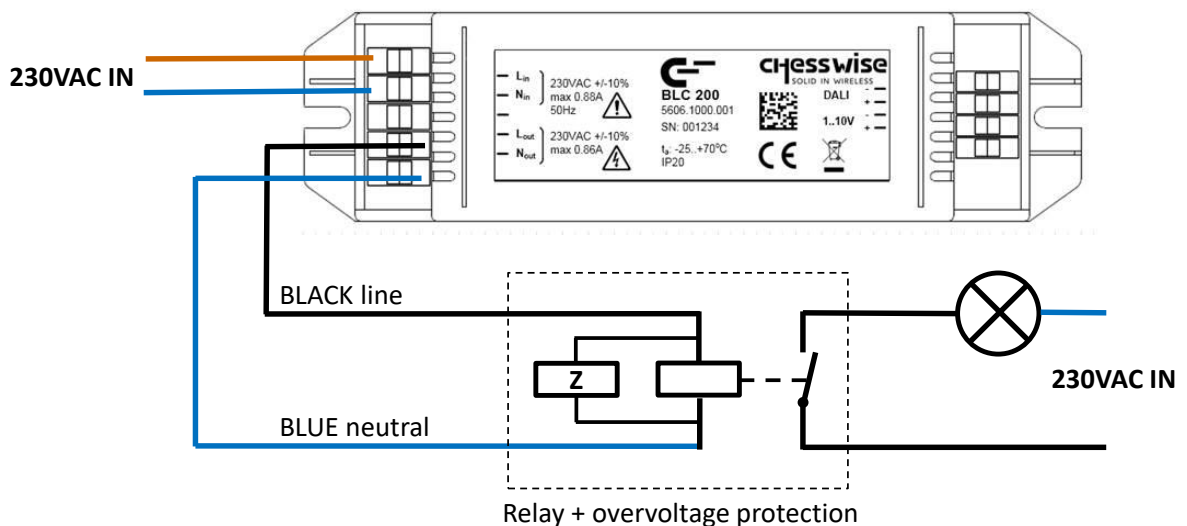

Connect the external 230VAC relay + overvoltage protection to the switched 230V output of the BLC200.

Configuration

When the BLC200 is powered, the connected lamp should go on. Use the iPad Mymesh commission app for configuration of the BLC200.

Usage

The BLC200 will control the connected driver and lamp.

Compliance



This product complies with the European directives and relevant standards for RED, REACH and RoHS. The BLC200 contains a 2.4 GHz radio. The applied frequency of the radio is within the band 2.401 – 2.482 GHz and the maximum transmit power is +4 dBm.

Hereby, Chess Wise B.V. declares that the radio equipment type BLC200 is in compliance with Directive 2014/53/EU. The full text of the EU declaration of conformity is available at chess.nl

Repair

Do not open this product. In case of failure the BLC200 must be replaced.



Recycling

Do not dispose this product as household waste, but bring it to an appropriate collection point for recycling.